

**ICSE Board**  
**Class IX Mathematics**  
**Sample Paper 3**

**Time: 2½ hrs**

**Total Marks: 80**

---

**General Instructions:**

1. Answers to this paper must be written on the paper provided separately.
  2. You will **NOT** be allowed to write during the first 15 minutes. This time is to be spent in reading the question paper.
  3. The time given at the head of this paper is the time allowed for writing the answers.
  4. This question paper is divided into two Sections. Attempt **all** questions from **Section A** and any **four** questions from **Section B**.
  5. Intended marks for questions or parts of questions are given in brackets along the questions.
  6. All working, including rough work, must be clearly shown and should be done on the same sheet as the rest of the answer. Omission of essential working will result in loss of marks.
  7. Mathematical tables are provided.
- 

**SECTION – A (40 Marks)**

*(Answer all questions from this Section)*

**Q. 1.**

(a) Calculate the amount and the compound interest on Rs. 6000 at 10% p.a. for

$1\frac{1}{2}$  years, when the interest is compounded half yearly. [3]

(b) If  $\frac{\sqrt{11}-\sqrt{7}}{\sqrt{11}+\sqrt{7}} = x - y\sqrt{77}$ , find the values x and y. [3]

(c) Sonu and Monu had adjacent triangular fields with a common boundary of 25 m. The other two sides of Sonu's field were 52 m and 63 m, while Monu's were 114 m and 101 m. If the cost of fertilization is Rs 20 per sq m, then find the total cost of fertilization for both of Sonu and Monu together. [4]

**Q. 2.**

- (a) Calculate the area of fig., ABCDE. Given  $DX = 9$  cm,  $DC = 5$  cm  $FC = 4$  cm and  $XB = 6$  cm.  
Also F and X are the mid-points of EC and AB respectively. [3]

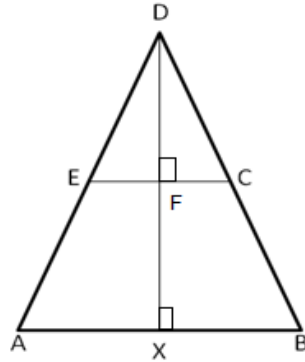

- (b) If two intersecting chords of a circle make equal angles with the diameter passing through their point of intersection, prove that the chords are equal. [4]
- (c) Find x, if  $(\sqrt[3]{4})^{2x+\frac{1}{2}} = (\sqrt[3]{8})^5$ . [3]

**Q. 3.**

- (a) Given  $\log x = a + b$  and  $\log y = a - b$ , find the value of  $\log \frac{10x}{y^2}$  in terms of 'a' and 'b'. [3]
- (b) The bisector of  $\angle A$  of a  $\triangle ABC$  meets BC at D and BC is produced to E. prove that  
 $\angle ABC + \angle ACE = 2\angle ADC$ . [3]
- (c) Using ruler and compass only, construct a trapezium ABCD, in which the parallel sides AB and DC are 3.3 cm apart;  $AB = 4.5$  cm,  $\angle A = 120^\circ$ ,  $BC = 3.6$  cm and  $\angle B$  is obtuse. [4]

**Q. 4.**

- (a) The following figure shows a right-angled triangle ABC with  $\angle B = 90^\circ$ ,  $AB = 15$  cm and  $AC = 25$  cm. D is a point in side BC and  $CD = 7$  cm. If  $DE \perp AC$ , find the length of DE. [4]

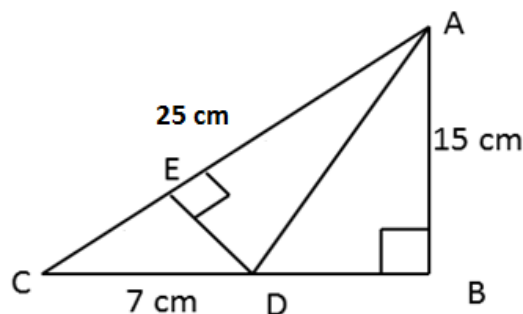

- (b) Prove that the interior angle of a regular pentagon is three times the exterior angle of a regular decagon. [3]
- (c) If  $\tan \theta + \cot \theta = 3$ , find the value of  $\tan^2 \theta + \cot^2 \theta$ . [3]

**SECTION - B (40 Marks)**

(Answer *any four questions* from this Section)

**Q. 5.**

- (a) Graphically solve the simultaneous equations:  
 $x - 2y = 1$ ;  $x + y = 4$  [4]
- (b) A and B together can do a piece of work in 15 days. If A's one day's work is  $\frac{3}{2}$  times B's one day's work; in how many days can A and B do the work alone? [3]
- (c) How many sides does a regular polygon have, each angle of which is of measure  $108^\circ$ ? [3]

**Q. 6.**

- (a) A person invests Rs. 5600 at 14% p.a. compound interest for 2 years. Calculate
- The interest for the first year.
  - The amount at the end of the first year.
  - The interest for the second year corrected to the nearest rupee. [3]
- (b) A point P lies on the x-axis and another point Q lies on the y-axis. [3]
- Write the ordinate of point P.
  - Write the abscissa of point Q.
  - If the abscissa of point P is -12 and the ordinate of point Q is -16; calculate the length of line segment PQ.
- (c)  $\triangle ABC$  is right angled at B. If  $m\angle A = 30^\circ$  and  $BC = 8$  cm. Find the remaining angles and sides. [4]

Q. 7.

(a) Simplify:  $\frac{3^{n+1}}{3^{n(n-1)}} \div \frac{9^{n+1}}{(3^{n+1})^{n-1}}$  [4]

(b) The area of an isosceles triangle is  $12 \text{ cm}^2$  and the base is  $8 \text{ cm}$  in length. Find the perimeter of the triangle. [3]

(c) In the figure,  $AC = CD$ . Prove that  $BC < CD$ . [3]

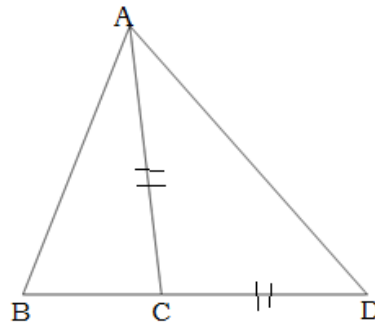

Q. 8.

(a) If  $\cos \theta = \frac{2\sqrt{mn}}{m+n}$ , find the value of  $\sin \theta$  ( $m > n$ ). [4]

(b) The mean of 5 numbers is 20. If one number is excluded the mean of the remaining numbers becomes 23. Find the excluded number. [3]

(c) 3 equal cubes are placed adjacently in a row. Find the ratio of the total surface area of the new cuboid to that of the sum of the surface areas of three cubes. [3]

Q. 9.

(a) In the given quadrilateral  $AD = BC$ , and P, Q, R and S are the midpoints of the sides AB, BD, CD and AC, respectively. Prove that PQRS is a rhombus. [4]

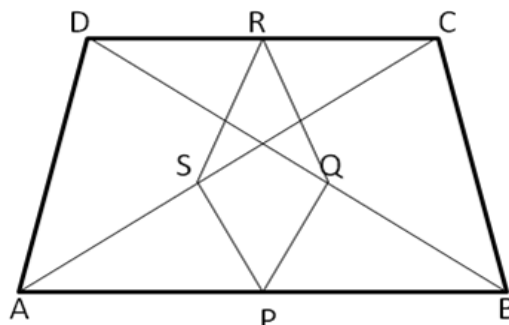

- (b) The distance (in km) of 40 engineers from their residence to place of work were found as follows: [3]

5	3	10	20	25	11	13	7	12	31
2	19	10	12	17	18	11	32	17	16
3	7	9	7	8	3	5	12	15	18
12	12	14	2	9	6	15	15	7	6

Construct a grouped frequency distribution table with class size 5 for the data given above taking the first interval as 0 - 5 (5 not included). What main feature do you observe from this tabular representation?

- (c) Solve:  $\log_x(8x - 3) - \log_x 4 = 2$  [3]

**Q. 10.**

- (a) Prove that  $\sqrt{5}$  is an irrational number. [4]

- (b) If  $\tan(\theta_1 + \theta_2) = \frac{\tan\theta_1 + \tan\theta_2}{1 - \tan\theta_1 \tan\theta_2}$ , find the value of  $(\theta_1 + \theta_2)$  given that  $\tan\theta_1 = \frac{1}{2}$  and

$$\tan\theta_2 = \frac{1}{3}. \quad [3]$$

- (c) If  $\frac{x^2 + 1}{x} = 4$ , find the value of  $2x^3 + \frac{2}{x^3}$ . [3]

**Q. 11.**

- (a) Factorise:  $4a^3b - 44a^2b + 112b$  [3]

- (b) Find the area of following figure: [3]

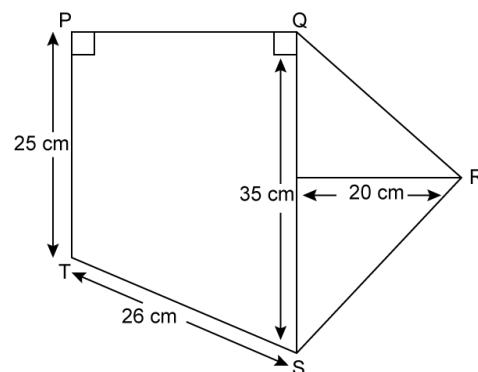

- (c) In  $\Delta ABC$ ,  $AB = AC = x$ ,  $BC = 20$  cm and the area of the triangle is  $250 \text{ cm}^2$ . Find  $x$ . [4]